

DFF
rising edge triggered DFF

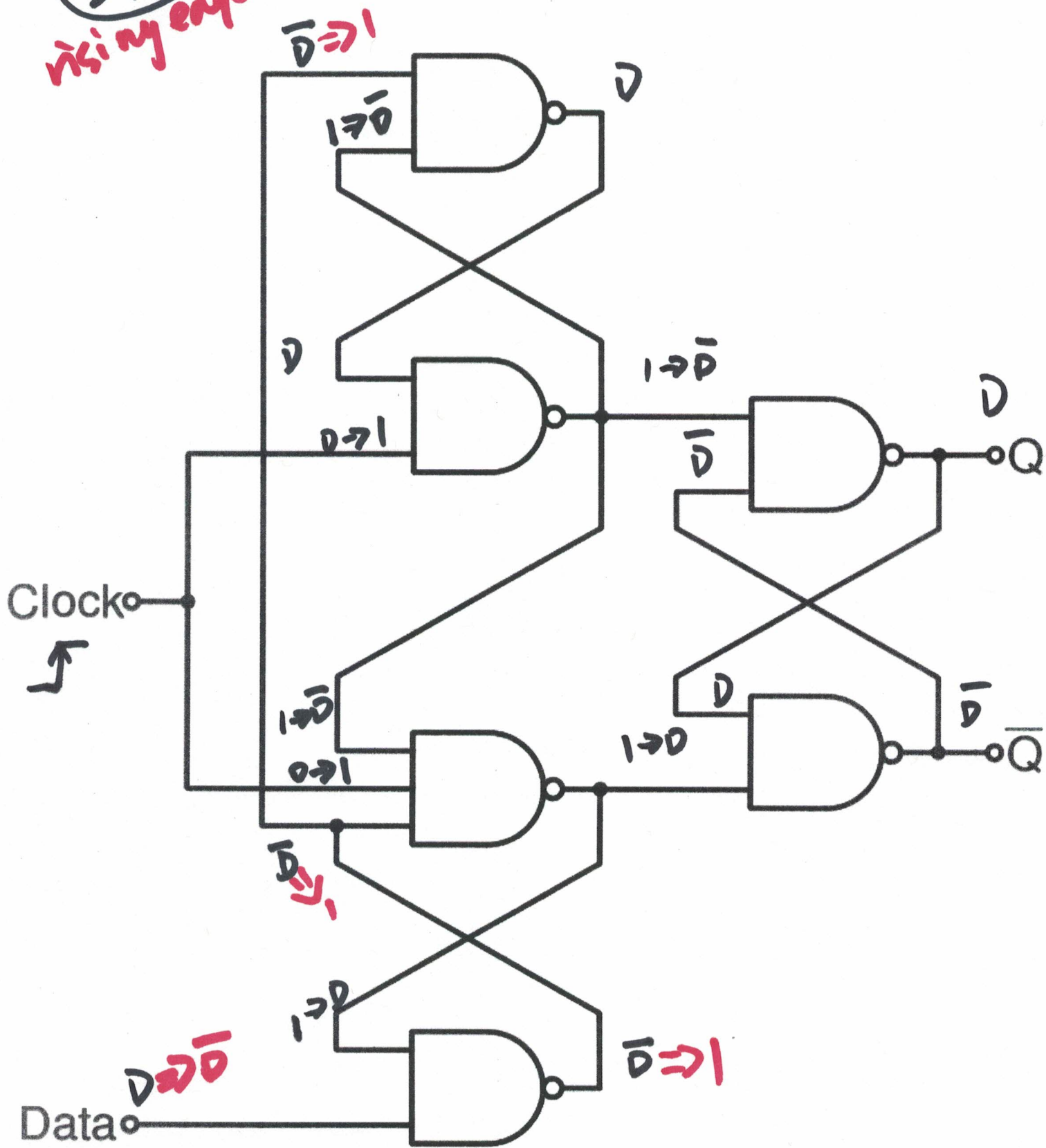

(DFF)

Synchronous
DFF

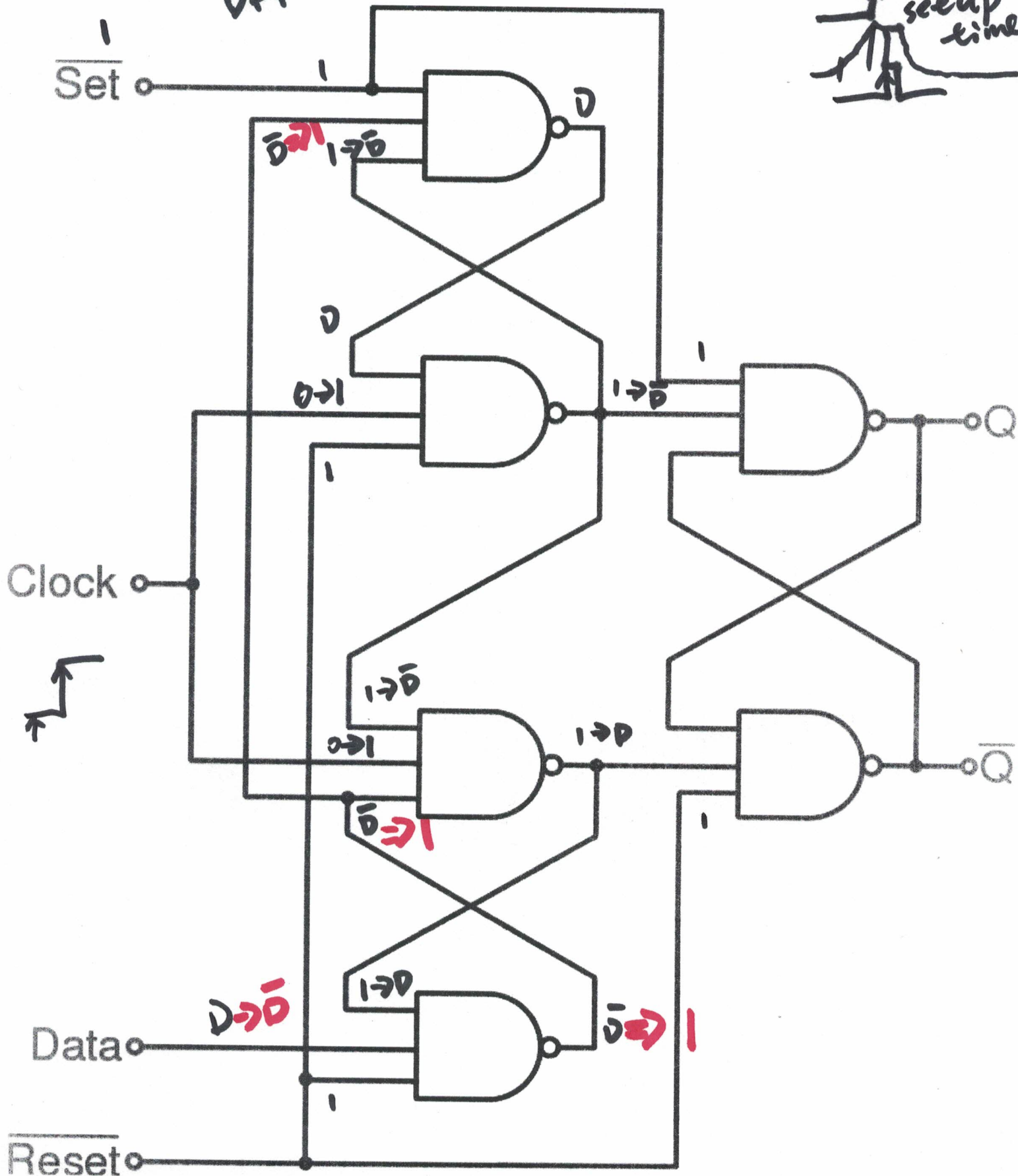
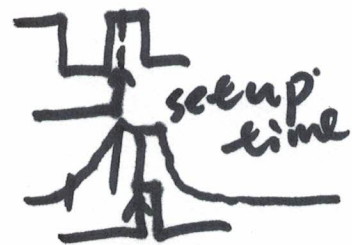

2